

**CONFIDENTIAL**

MG/233

**SERVICE MEMORANDUM**

23 October 1958

STEERING BALL SOCKET ASSEMBLY

'MGA' & 'MAGNETTE'

It is possible with high-pressure greasing apparatus to blow out or distort the washer at the base of the ball socket and a new form of ball socket was introduced at the under-mentioned car numbers to obviate this trouble:

'MGA'

Car No. 55545 (RHD)

" " 53875 (LHD)

'MAGNETTE'

Car No. 32032 (RHD)

" " 31946 (LHD)

Existing sockets can be modified by drilling a hole 1/16" diameter in the washer at the base of the socket and fitting a Belleville washer 'A' (Part No. ACH6170) and the special fibre washer 'B' (Part No. ACH6173), as shown in the sketch below.

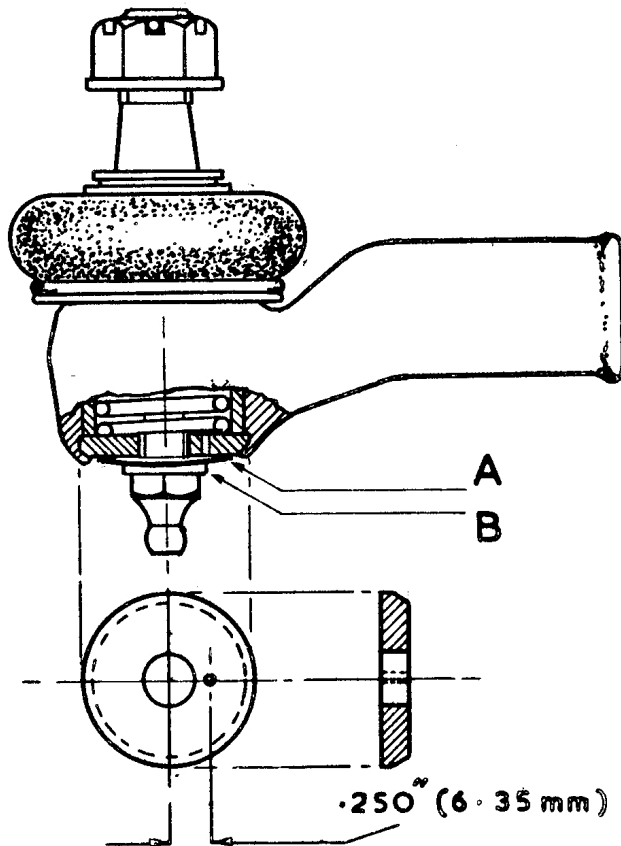

It is most important to ensure that only the correct fibre washer (Part No. ACH6173) is fitted. An ordinary commercial fibre washer must not be used.