

AKD1296

The



**SERIES MGA
TWIN CAM**

SERVICE PARTS LIST



AKD1296

The



**SERIES MGA TWIN CAM
SERVICE PARTS LIST
(THIRD EDITION)**

This List cancels the Second Edition of Part No. AKD1296 and embodies all information issued up to and including Parts List Amendment No. PMG/544.

Issued by

**B.M.C. SERVICE LIMITED
COWLEY · OXFORD · ENGLAND**

Telephone - - - - - Oxford 7777
Telex - - - - - Oxford Telex 83145 and 83146
Telegrams - - - - - Mowog, Telex, Oxford



Cables - - - - - Mowog, Oxford, England
Codes - - - - - Bentley's, Bentley's Second Phrase, A.B.C.
(5th and 6th Editions), Western Union and Private

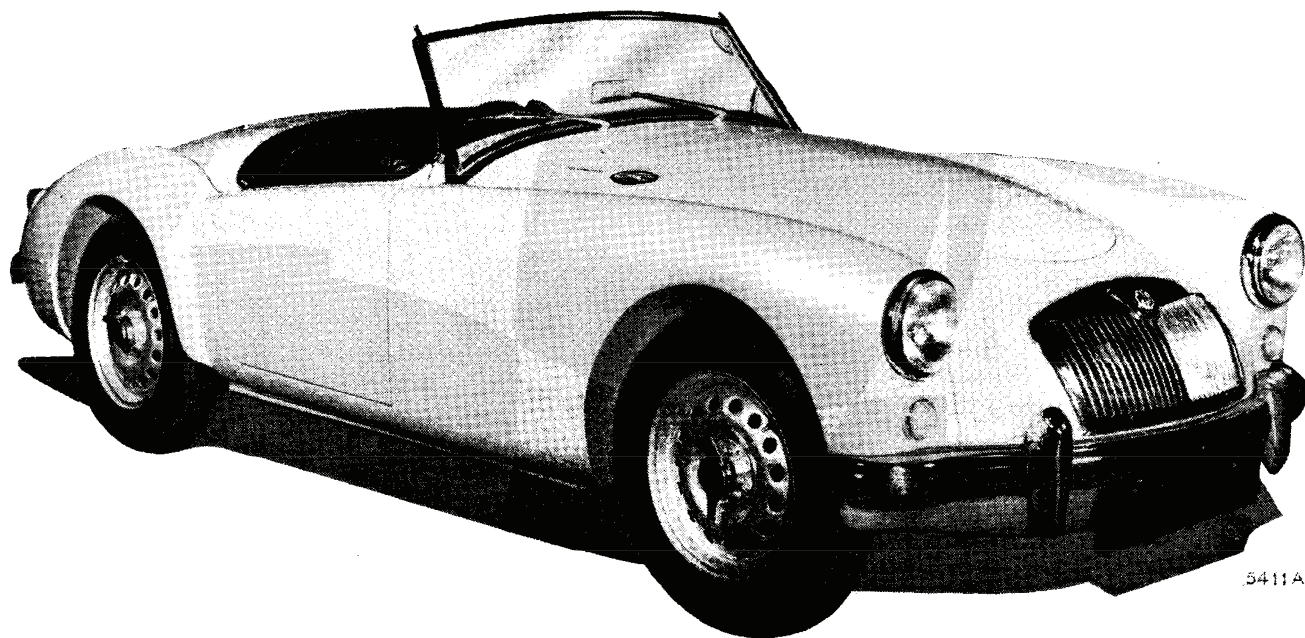

5411A

POWER UNIT SERIAL NUMBER CODING

The engine number prefix comprises a series of letters and numbers, presenting in code the capacity, make, and type of unit gearbox and ancillaries fitted, and the type of compression together with the serial number of the unit.

1st PREFIX GROUP—Cubic capacity, make, and type

1st Prefix number: 16=1600 c.c.
 1st Prefix letter: G=MG
 2nd Prefix letter: B=Variation of engine type.

2nd PREFIX GROUP—Gearbox and ancillaries

U—Centre gear change gearbox

3rd GROUP—Compression and serial number

H—High compression } and serial number of unit
 L—Low compression }

CODE EXAMPLE

16GB-U-H101

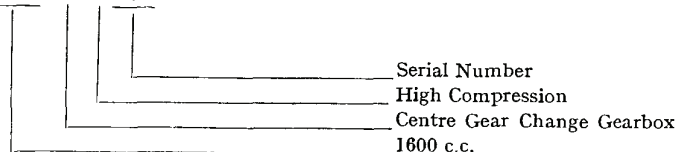

CAR SERIAL NUMBER CODING

Car number identification of the MGA Twin Cam consists of two letters and one figure followed by the Chassis Number.

YD1/—Right Hand Drive (Home)
 YD2/—Right Hand Drive (Export) } 2-Seater Tourer
 YD3/—Left Hand Drive

YM1/—Right Hand Drive (Home)
 YM2/—Right Hand Drive (Export) } Coupé
 YM3/—Left Hand Drive

CODE EXAMPLE

YD3/501

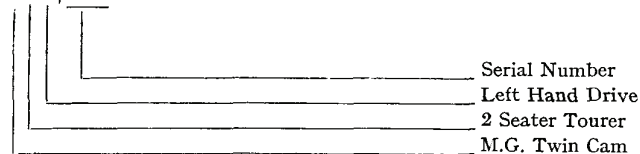

Introduction

The range of parts in this List covers all serviceable components on all models to the standard specifications. Where the part is confined to one specification this is clearly defined in the 'Quantity' and or 'Remarks' column, and where the part listed is not serviced this is indicated by the letters N.S.P. in the 'Part Number' column.

The components in the plate illustrations are identified by numbers which correspond with the illustration reference appearing on the facing page in the column immediately following the part number.

It is essential first to identify the part against the illustration in the appropriate section of the List and make use of the illustration reference number to locate the part number and official description on the adjacent page.

When using the List it must be noted that each assembly (or sub-assembly) is shown as the **first item** and followed immediately by the individual components of the assembly, which are 'offset' for easy identification. It must be clearly understood that such assemblies (or sub-assemblies) will only be supplied complete with all their components when ordered against the assembly (or sub-assembly) part number. It will be appreciated, however, that the individual components of the assembly (which are listed immediately below and offset) can themselves be supplied separately, provided they are ordered against their individual part numbers. Note that the quantities shown are the quantity per vehicle, and not the quantity per component.

Example:

CONNECTING RODS—BEARINGS

Connecting rod and cap + 2 (Nos. 2 and 4 cylinders)	AJH5307	2
Connecting rod and cap + 2 (Nos. 1 and 3 cylinders)	AJH5313	2
Bolt for cap	AEH435	8
Washer for bolt	6K881	4

We reserve the right to make changes or improvements in the construction or equipment of our products at any time. It is our general policy, however, to supply components to the latest specification.

Where a modification has taken place to a part, or a new part issued replacing the original part, this is indicated by the inclusion of the new part number under 'Modifications'.

Owner's Guide for Ordering Parts

Obtain your parts from the local B.M.C. Distributor or Dealer, who stocks only B.M.C. genuine and warranted parts.

- (1) In order to ensure prompt and correct execution of orders it is essential that the following instructions are adhered to:
 - (a) Always state the **car and engine numbers** complete with prefixes and suffixes (see page iii).
 - (b) Always **state the colour** of carpets, painted items, trim items, etc.
 - (c) Give **part numbers** and **description** (prefix letters to part numbers must always be quoted).
 - (d) **Quantity required**, bearing in mind that the quantities shown are the quantity per vehicle.
 - (e) **If ordering for dispatch give definite forwarding instructions**, i.e. sea, air freight, air parcel service, post, passenger goods train, road service, or collection.
- (2) When cabling or telegraphing the local Distributor or Dealer use the part number and give the **car number**. **Confirm your cable or telegram by letter, or order**, at once. Give sufficient postal address for a parcel to find you. If you are away from home give **your home address in addition** to the dispatching instructions. Remember when sending a telegraphic order that **your name and address must be telegraphed as a message**. If this is not done the order will arrive without any indication of the sender's address, as your signature and address on the back of the telegram form is not telegraphed. Always write the quantity required of any particular part in words.
- (3) **Claims under Warranty**
 Claims for the replacement of material or parts under Warranty must always be submitted to the supplying Distributor or Dealer, or, when this is not possible, to the nearest Distributor or Dealer, informing them of the vendor's name and address.
- (4) **Replacement Unit Schemes**
 Where service replacement units are available this is clearly indicated by a bold letter (**R**) against the item at the end of the 'Description' line. Details of these and the terms and method of replacement are published in the local press and trade periodicals. You are advised to consult the local Distributor or Dealer for full details.

LOCATION OF SERIAL NUMBERS

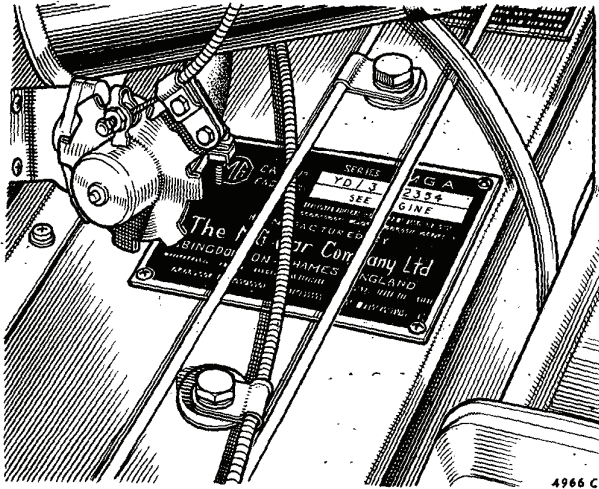

The **Car Number** is stamped on a plate secured to the top left-hand side of the dash panel

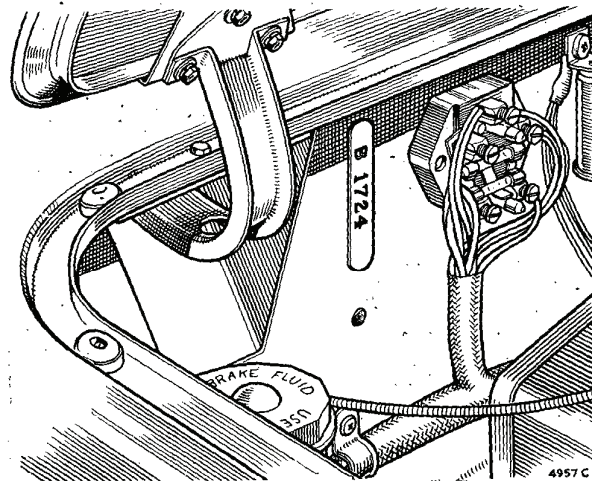

The **Body Number** is stamped on a plate secured to the bulkhead between the right-hand bonnet hinge and the fuse block.

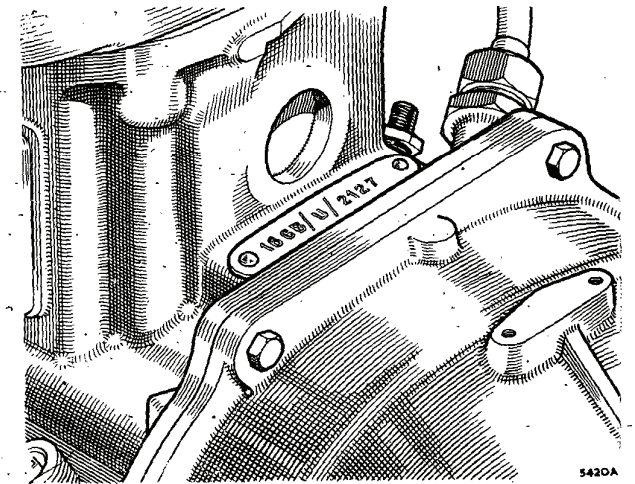

The **Engine Number** is stamped on a plate secured to the rear of the engine behind the cylinder block

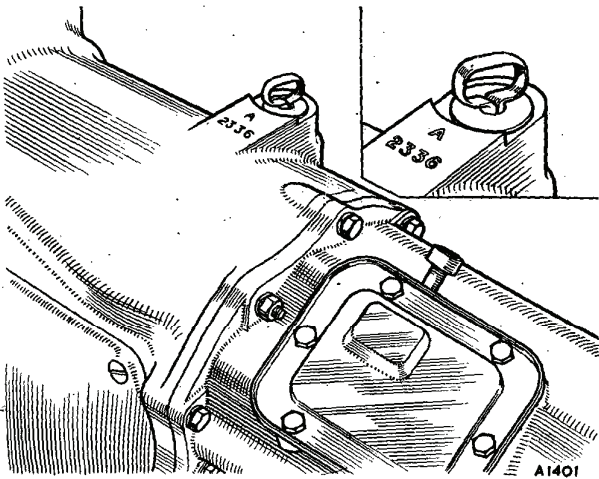

The **Gearbox Number** is stamped on the top of the gearbox casing adjacent to the dipstick

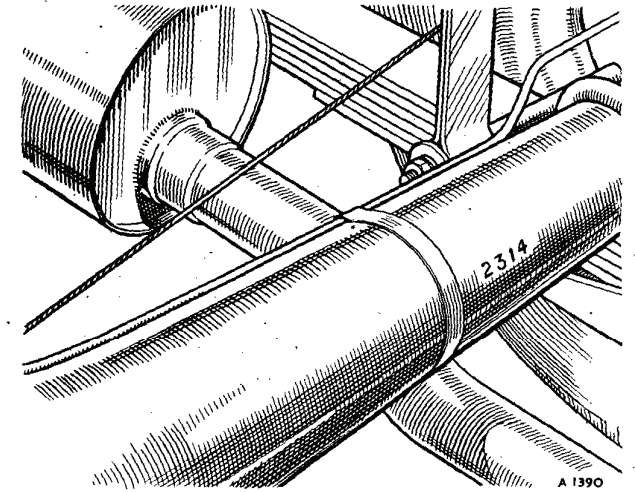

The **Rear Axle Number** is stamped on the front of the axle tube on the left-hand side adjacent to the spring seat

Instructions to Dealers

Modifications will be covered by the issue of Parts Amendment Sheets as required and also by the periodical reissue of the Part Number Index. Each issue of this Index is identifiable by its issue number and supersedes the previous issue, which should be destroyed. This Part Number Index should be kept with this List, for which purpose it is suitably punched.

In practice, first identify the items with the aid of the appropriate illustration. This provides a reference to the part number and official description appearing on the facing page. Now turn up the part number in the Part Number Index. Any modification will be indicated by the Parts Amendment Sheet number appearing in the adjacent column, and reference to this will provide the information necessary to ensure the issue of the correct part. If no Amendment Sheet number is indicated against the part number in the Part Number Index the part is clear for issue.

New parts introduced subsequent to the printing of this Parts List may be traced with the aid of the separate Index to Improvements and Alterations. They will be included in the Part Number Index as this is reissued and appropriately cross-referenced.

Certain classes of items are stocked and issued in **cartons, packets, etc., only**, and these are indicated in the Parts List by a figure in the 'Unit of Issue' column showing the quantity per package.

It is most important that orders should quote quite clearly the number of **packets** required, the word 'packets' (or the abbreviation 'pkt.') being used in every case.

If the word 'packet' is not used confusion may arise concerning the quantity actually required, with consequent delay in order handling.

While the quantity of units per pack indicated in the 'Unit of Issue' column in this Parts List provides a ready guide, it is always advisable to check the latest information regarding items in this category by referring to the Master Price List.

In addition a number of prices in the Price List are shown for a dozen (i.e. the abbreviation 'doz.' appears between the part number and the price), in which case the item is sold in 'dozens' only, and units of one dozen must be ordered, quoting the word 'dozen' or the

abbreviation 'doz.'; thus, should 48 be required, the order should state clearly '4 doz.'. Again, confusion can result if this is not done and over- or under-issue may occur.

NOTE.—Oversize and undersize replacement parts are tabulated at the end of the engine section.

The following abbreviations are used:

Not U.K. indicates 'Export only'.

RHD indicates 'Right-hand drive'.

LHD indicates 'Left-hand drive'.

R/H indicates 'Right-handed'.

L/H indicates 'Left-handed'.

R.H.T. indicates 'Right-hand thread'.

L.H.T. indicates 'Left-hand thread'.

N.S.P. indicates 'Non-serviceable part'.

O/S indicates 'Oversize'.

U/S indicates 'Undersize'.

O/D indicates 'Outside diameter'.

R at the end of the description indicates that reconditioned units are available under the B.M.C. Exchange Parts Service.

Where commencing and finishing numbers are quoted they are preceded by the following symbols to indicate the unit to which they apply:

(E) in the case of engine numbers.

(C) in the case of car numbers.

(G) in the case of gearbox numbers.

(FA) in the case of front axle numbers.

(RA) in the case of rear axle numbers.

(B) in the case of body numbers.

Bundy pipes are supplied completely finished and to the correct length but not shaped. They may be delivered straight or coiled according to their length and mode of delivery.

S.U. carburettor needles are supplied under the one part number AJH5292 and the individual needles are identified by the letter symbols stamped on the shoulder. When ordering replacement needles it is essential to quote the identification symbol in addition to and immediately following the part number.

IMPORTANT

B.M.C. SERVICE PARTS

When purchasing replacement parts or having repairs done owners are requested to see that a label similar to the one illustrated here is attached to the invoice rendered. These labels are issued by the Company and constitute a guarantee that genuine parts are supplied.

No better vehicle maintenance service exists in the world than that provided by the manufacturers and no vehicle demands less attention, but it is unfair to the manufacturers to expect the continuance of their support if the structure of the vehicle has been



disturbed by the use of replacements that are not genuine B.M.C. parts.

Replacement parts that are not of genuine B.M.C. manufacture cannot be relied upon to be of B.M.C. specification, material, and workmanship, and therefore the manufacturers cannot be expected to extend their Warranty to vehicles which have been fitted with parts not of their manufacture.

All Authorized B.M.C. Distributors and Dealers are under contract to supply only genuine B.M.C. parts.